

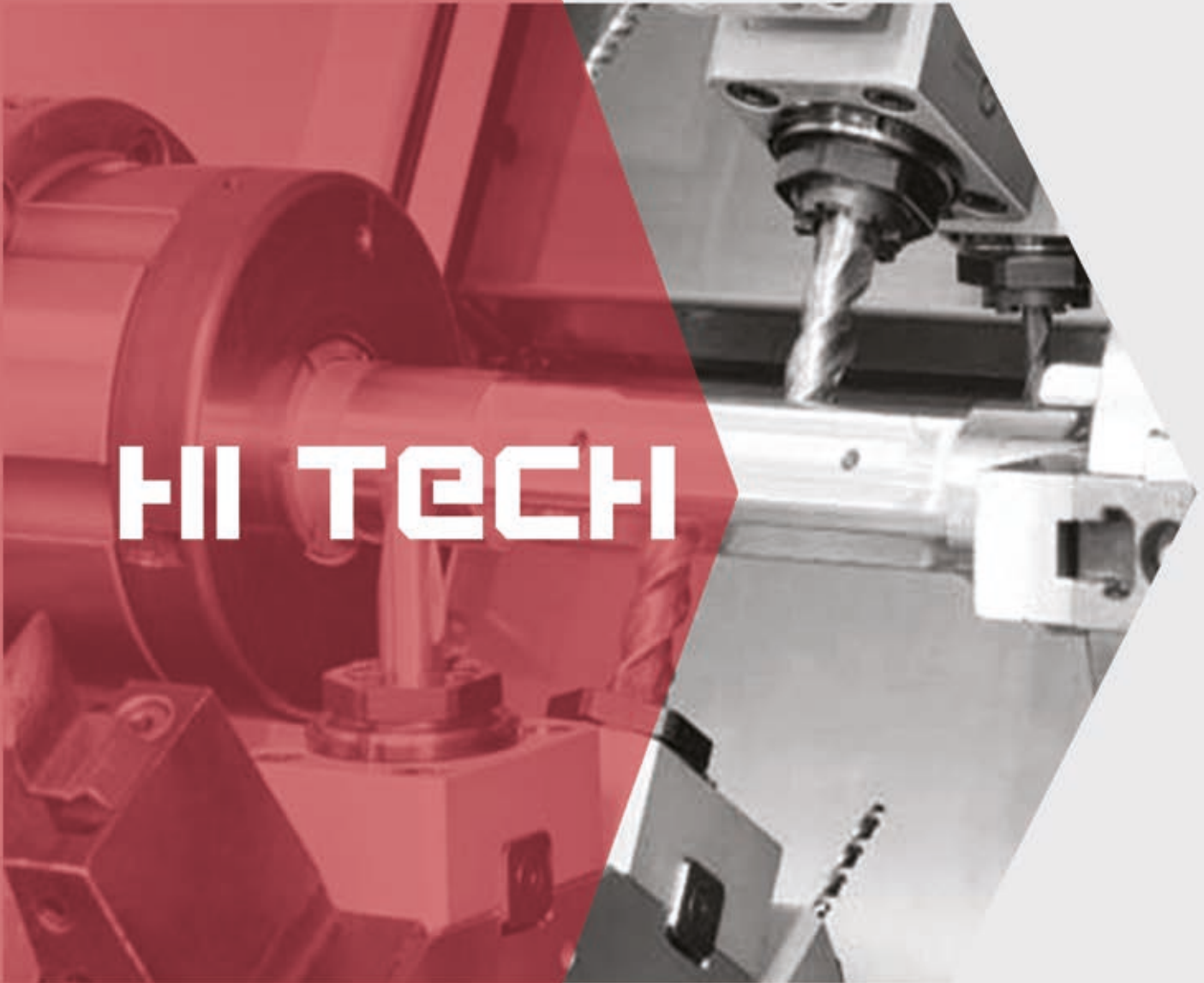

**HI TECH**



## CHI SIAMO ABOUT US

### L' ALTA TECNOLOGIA È UNA NOSTRA PRIORITÀ HIGH TECHNOLOGY IS OUR PRIORITY

Offriamo una vasta gamma di prodotti per l'industria, ricercando sempre la più alta qualità, i migliori materiali e ritenendo l'innovazione tecnologica una prerogativa.

We offer a wide range of products for the industry, always seeking the highest quality, the best materials and considering technological innovation is the prerogative.

Siamo a servizio delle industrie operanti nei settori energetico, alimentare, oleodinamico, pneumatico, impiantistico e terziario, offrendo un'ampia scelta di linee di prodotti, tra le quali:

We are at the service of the industries operating sectors such as energy, food, hydraulic, pneumatic, systems and service, offering a wide range of product lines, including:

- Articoli tecnici per l'industria
- Technical items for industry
- Attrezzature per macchine utensili
- Machine tools equipments
- Materiali di consumo
- Consumable materials

Le competenze tecnico-commerciali, l'esperienza acquisita dal nostro personale e la stretta collaborazione coi principali fornitori, sono a garanzia di un efficiente ed efficace servizio pre e post-vendita. Inoltre, grazie a partnership con aziende specializzate e collaboratori altamente qualificati, siamo in grado di presentare soluzioni ad-hoc per richieste particolari.

The technical and commercial skills, the experience are gained by our staff and close collaboration with leading suppliers which are guarantee an efficient and effective before and after-sale's service. Moreover, thanks to partnerships with expert companies and highly qualified employees, we are able to present ad-hoc solutions for special requests.

Il fine ultimo di HI TECH è quello di proporre prodotti, offrire soluzioni e mettere a disposizione la propria conoscenza nel settore per soddisfare le esigenze dei nostri clienti.

The ultimate goal of HI TECH is to propose products, offers solutions and make available their knowledge in the field to meet our customers' needs.



## Missione Mission

HI TECH: la nostra missione è quella di offrire soluzioni per soddisfare le specifiche esigenze del cliente attraverso la produzione di strumenti e di componenti standard e speciali, anche per applicazioni di elevata complessità. I fattori chiave sono: l'alto livello di know-how; la gestione interna di tutto il processo produttivo; la sinergia tra ingegneria e lavoro; la partnership a lungo termine con i migliori clienti e fornitori. HI TECH ha un forte atteggiamento "Si può fare", in termini di continua ricerca delle migliori soluzioni al fine di soddisfare le esigenze del cliente. Ogni nuovo progetto è realizzato attraverso il coinvolgimento attivo di tutte le risorse, dal presidente al lavoratore, con l'obiettivo di garantire l'eccellenza del risultato. Qualità totale, soddisfazione del cliente e miglioramento continuo: questi sono i valori che condivide HI TECH con i suoi dipendenti, clienti e fornitori ogni giorno.

HI TECH: our mission is to offer solutions to meet specific customer requirements through the production of tools and standard and special components, even for highly complex applications. The key factors are: the high level of know-how; the internal management of the entire production process; the synergy between engineering and work; the long-term partnership with the best customers and suppliers. HI TECH has a strong attitude of "It can be done", in terms of continuous research of the best solutions in order to meet customer's needs. Each new project is implemented through the active involvement of all resources, from the president to the worker, in order to guarantee the excellent result. total quality, customer satisfaction and continuous improvement: these are the values that HI TECH shares with its employees, customers and suppliers every day.



## Soluzioni e Progetti Solutions & Projects

HI TECH si distingue dai concorrenti per la completezza della sua gamma di prodotti e soluzioni, ma anche per la sua competenza tecnica e qualitativa. La Società progetta e produce strumenti, soluzioni, ingegneria e componenti speciali per le esigenze del cliente. I componenti speciali sono a volte realizzati unicamente su richiesta per esigenze specifiche del cliente. In ogni progetto si è impegnati nella ricerca delle migliori soluzioni tecniche e produttive, con l'obiettivo di "fornire il miglior prodotto per un uso specifico, con la migliore qualità al miglior prezzo e tempo".

HI TECH stands out from its competitors for its complete range of products and solutions, but also for its technical expertise and quality. The Company designs and manufactures tools, solutions, engineering and special components for customer's needs. Special components are sometimes performed solely on request for specific customer's needs. In every project we are engaged in finding the best technical and productive solutions, with the aim of "providing the best product for a specific use, with the best quality at the best price and time".

# Utensili per asportazione truciolo

## Tornitura / Turning

Utensili per tornitura esterna e interna  
Tools for external and internal turning



## Fresatura / Milling

Fresatura a fissaggio meccanico e integrale  
Milling with mechanical and integral mounting



## Foratura / Drilling

Foratura a fissaggio meccanico e integrale  
Drilling with mechanical and integral mounting



## Barenatura / Boring

Teste di barenatura a regolazione micrometrica  
Boring head with micrometric adjustment



## Maschiatura / Tapping

Maschiatura ad asportazione ed a deformazione  
Tapping for cutting and forming

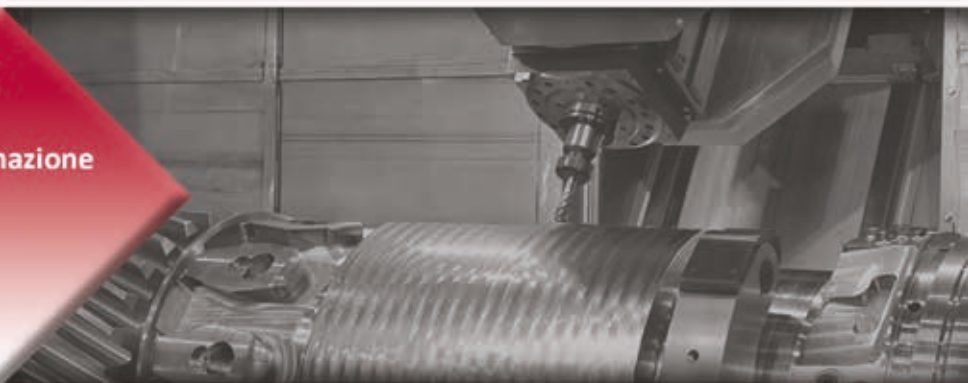

# Tools for metal cutting

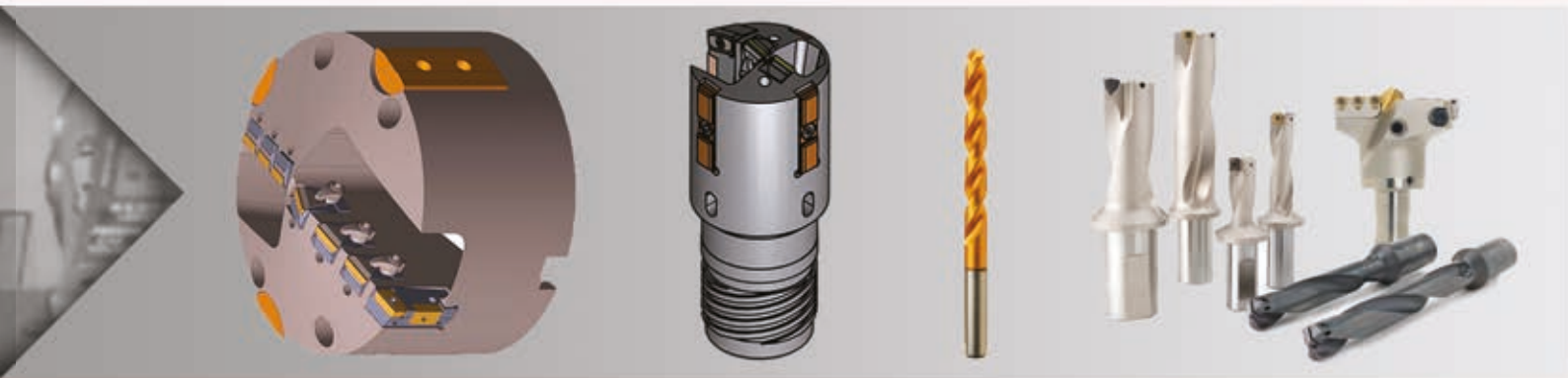

# Attrezzature per macchine utensili

## Mandrini / Chucks

Mandrini porta utensili  
Tools holding chucks



## Morse e Cubi / Vises and Cubes

Attrezzature di bloccaggio per presa pezzo  
Workpiece clamping equipments



## Pinze / Collets

Pinze per mandrini  
Collets for chucks



## Portautensili Motorizzati / Motorized Toolholders

Utensili rotanti e statici per torni CNC  
Rotating and static tools for CNC lathes



## Mandrini Autocentranti / Selfcentering chucks

Mandrini autocentranti e piattaforme a comando manuale  
Mandrini autocentranti automatici  
Trascinatori frontali autoforzanti  
Mandrini automatici porta pinze  
Manual control selfcentering and independent chucks  
Autom selfcentering chucks  
Autofretting face drivers with morse taper  
Automatic collet chucks



# Equipments for machine tools



## Strumenti di misura / Measuring tools

Possiamo fornire un'ampia scelta di strumenti come: Presetter per la misurazione e preregistrazione degli utensili, Macchine tridimensionali per la rilevazione di quote, Macchine ottiche, Altimetri digitali, Rugosimetri, Rotondimetri, Visualizzatori di quota, Righe ottiche, Misuratori laser, Misuratori della forza di serraggio, Misuratori di spessori, Misuratori di temperatura, Micrometri analogici o digitali millesimali per interno ed esterno, Calibri analogici o digitali per interno ed esterno, Comparatori, Porta-Comparatori e molto altro.

We offer a wide range of instruments, like: Presetter for measuring and tool pre-registration, Three-dimensional machines for the detection of units, Optical equipment, Digital altimeters, Roughness, Roundness, Digital readout, Optical scales, Laser measurers, Measuring instruments of clamping force, Thickness measurers, Temperature measurers, Analog or digital millesimal micrometers for internal and external, Analog or digital measurers internal and external, Dial gauges, Dial gauges holder and more.

## Lubrificanti / Lubricants

Possiamo fornire una vasta scelta di prodotti destinati all'utilizzo per macchine utensili, per l'impiantistica e componenti, per la lavorazione dei metalli sia da taglio che da asportazione e per la lubrificazione, tra cui: Oli lubrificanti, Lubrorefrigeranti integrali ed emulsionabili minerali o sintetici.

We can provide a wide range of products intended to be used for machine tools, for the plant and components, for the metal working for both cutting and removal and for lubrication, including: Lubricating oils, Integral coolants and mineral or synthetic emulsifiables.

## Abrasivi / Abrasive

Vi offriamo una vasta scelta di prodotti innovativi ed altamente efficaci, selezionati tra le migliori marche, tra cui: Dischi lamellari da taglio e sbavo, Dischi in carta o in tela o in fibra, Dischi compressi, Mole con foro o su gambo, Ruote lamellari con foro o su gambo, Ruote compatte convolute, Nastri, Fogli, Rotoli, Strisce, Anelli, Coni, Rullini, Spazzole metalliche e Utensili speciali.

We offer a wide range of innovative and highly effective products, selected from the best brands, including: Cutting off and grinding flap discs, Paper or canvas or fiber discs, Compressed discs, Grinding wheels with hole or shank, Flap wheels with hole or shank, Convolute compact wheels, Belts, Sheets, Rolls, Strips, Spiralbands, Cones, Rolls, Metal brushes and special tools.

## Arredamenti / Furnishing

Possiamo fornire varie soluzioni, dallo stoccaggio alla movimentazione del materiale, fino ai complementi d'arredo, selezionando tra le migliori marche quei prodotti che si distinguono per affidabilità, qualità e praticità, come: Magazzini verticali automatici, Banchi e postazioni da lavoro, Scaffali a cassette, Sistemi di scaffalatura, Armadi per materiali, Cassettiere, Carrelli, Sistemi per il trasporto e la custodia del materiale, Cassette e Contenitori, Materiale di suddivisione ed etichettatura, Armadi per spogliatoi, Panchine e molto altro.

We can provide various solutions for material storage and handling up to furnishing, selecting from top brands products which are distinguished by reliability, quality and practicality, such as: Automatic vertical storages, Desks and workstations, Sliding drawers, Shelving systems, Cabinets for material, Tool chests, Trucks, Transport systems and the material cases, Boxes and containers, Partition materials and labeling, Lockers for changing rooms, Benches and much more.

## Utensili manuali / Hand tools

L'utensileria che Vi proponiamo copre una vasta gamma di articoli (impossibile elencarli tutti), come ad esempio: Chiavi dinamometriche, combinate e fisse, Bussole, Cricchetti, Giraviti a taglio, a croce e torx, Pinzetterie, Forbici, Mazzuole anti-rimbalzo, Martelli e tantissimi altri.

The tools that we offer covers a wide range of items (impossible to list them all), such as: Torque, combined and fixed wrenches, Sockets, Ratchets, Slotted, cross and torx screwdrivers, All kind of pliers, Scissors, Anti-rebound mallets, Hammers and many others.

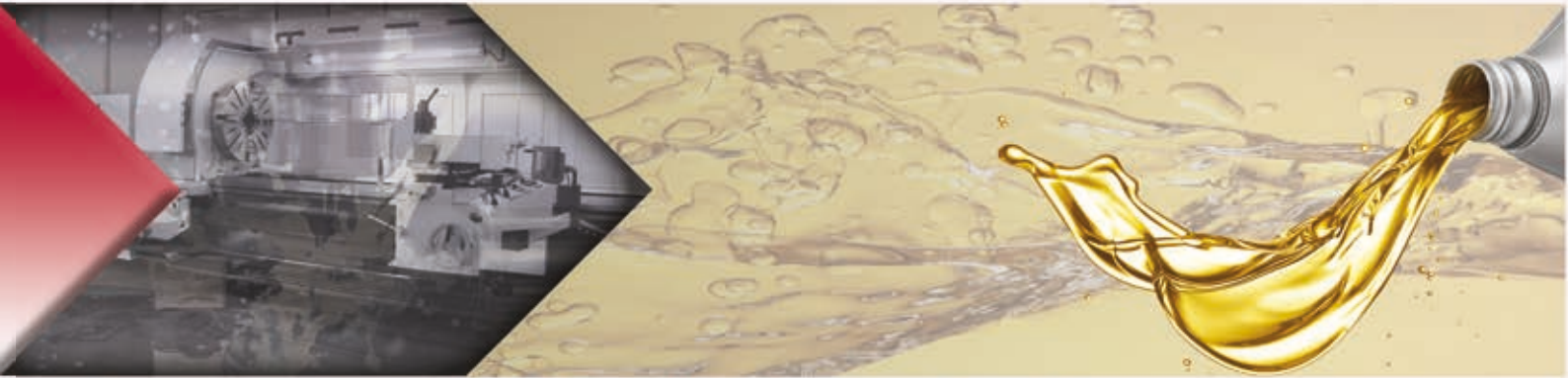
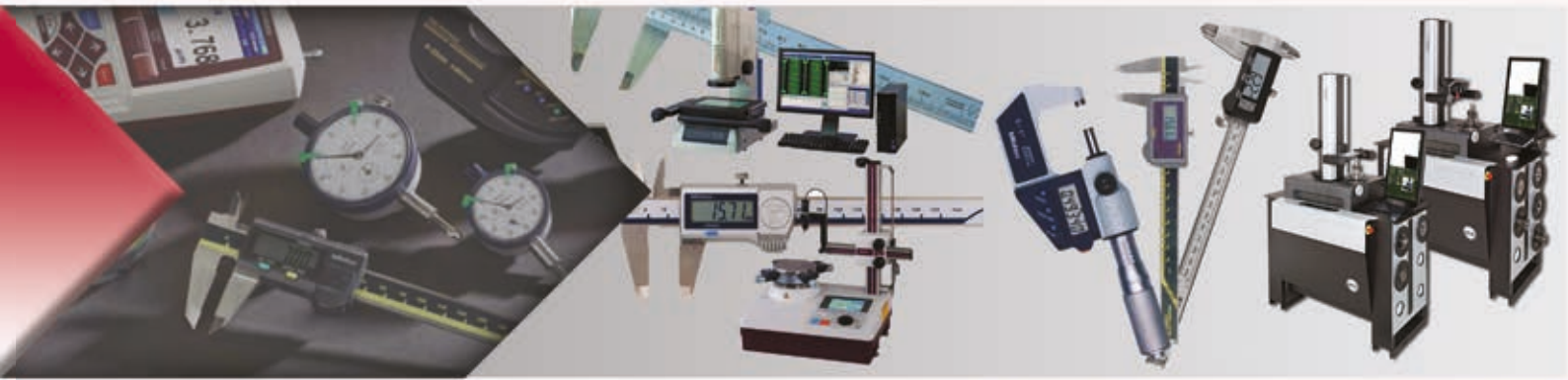

# Utensili speciali

**Foratura Profonda**  
**Deep Drill**

**Carotatura**  
**Core Drilling**

**Allargatura e Barenatura**  
**Widening and Boring**

**Levigatura**  
**Smoothing**

**Utensili per l'industria Ferroviaria**  
**Tools for the Railway Industry**

# Special tools

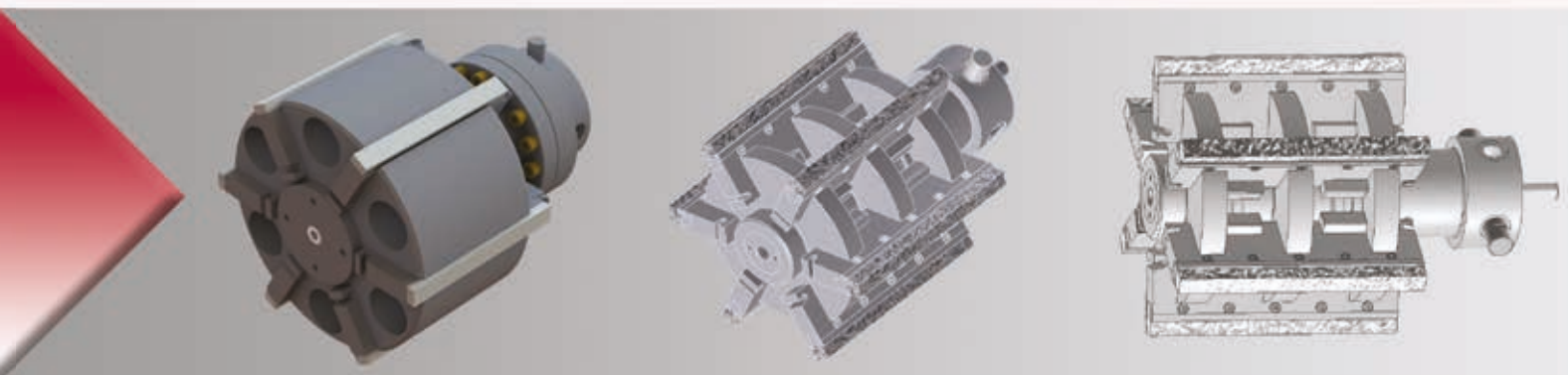
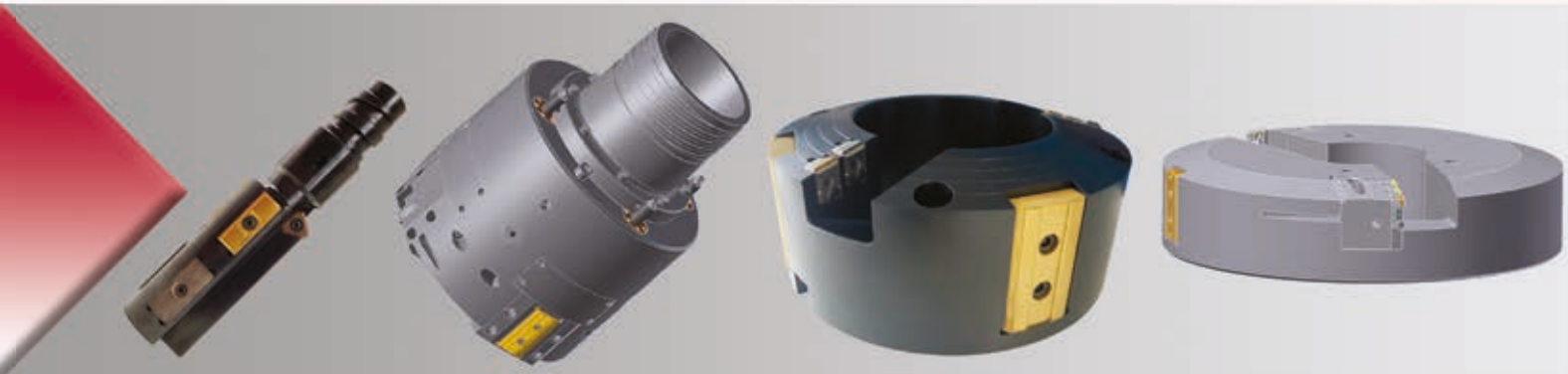
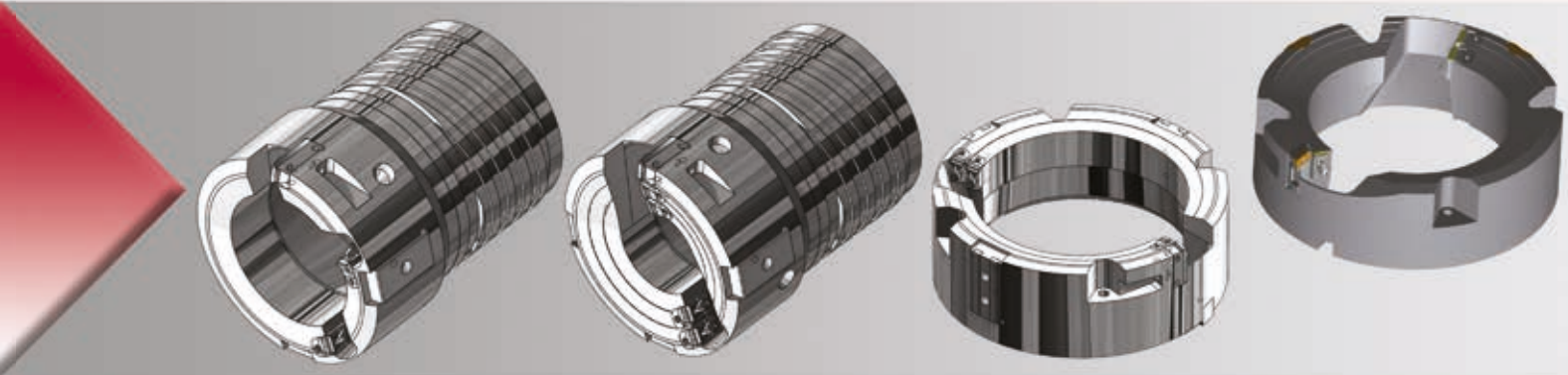
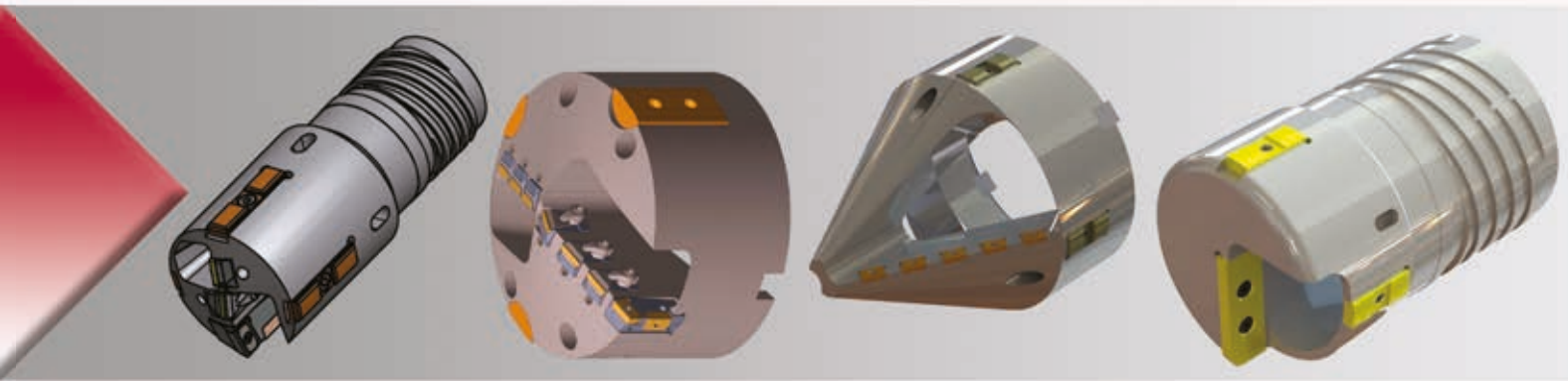



**CONTATTATECI**  
**CONTACT US**

---

C.so Europa 18  
20045 Lainate (MI) Italy

Tel.: +39 (0)2-93.11.998

Email: [info@hitech-srl.it](mailto:info@hitech-srl.it)  
[www.hitech-srl.it](http://www.hitech-srl.it)